



## Cambridge IGCSE™ (9–1)

CANDIDATE  
NAME

CENTRE  
NUMBER

--	--	--	--	--	--

CANDIDATE  
NUMBER

--	--	--	--



**CO-ORDINATED SCIENCES**

**0973/41**

Paper 4 Theory (Extended)

**October/November 2022**

**2 hours**

You must answer on the question paper.

No additional materials are needed.

### INSTRUCTIONS

- Answer **all** questions.
- Use a black or dark blue pen. You may use an HB pencil for any diagrams or graphs.
- Write your name, centre number and candidate number in the boxes at the top of the page.
- Write your answer to each question in the space provided.
- Do **not** use an erasable pen or correction fluid.
- Do **not** write on any bar codes.
- You may use a calculator.
- You should show all your working and use appropriate units.

### INFORMATION

- The total mark for this paper is 120.
- The number of marks for each question or part question is shown in brackets [ ].
- The Periodic Table is printed in the question paper.

This document has **28** pages.

1 (a) Fig. 1.1 is a diagram of the male reproductive system in humans.

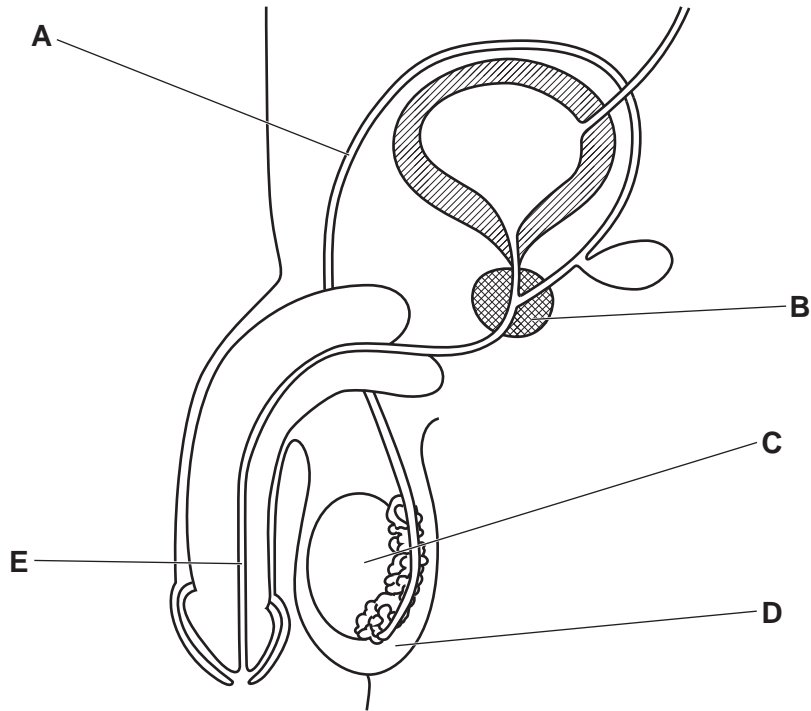

Fig. 1.1

State the letter from Fig. 1.1 that represents the part:

- where meiosis occurs .....
- which secretes fluid for sperm to swim in .....
- which carries urine .....
- which produces sperm. ....

[4]

(b) Fig. 1.2 is a drawing of a sperm cell.

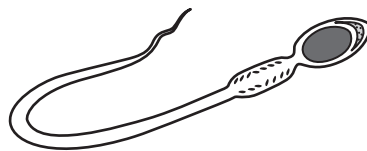

Fig. 1.2

Label Fig. 1.2 to identify **two** features of sperm that adapt it for reproduction.

[2]

3

- (c) Describe the difference between the arrangement of chromosomes found in the nuclei of sperm and those in a zygote.

.....  
..... [1]

- (d) Sperm and egg cells are specialised for their function of reproduction.

The boxes on the left show some other specialised cells.

The boxes on the right show some functions.

Draw lines to link each specialised cell with its function.

ciliated

palisade mesophyll

root hair

absorption

movement of mucus

photosynthesis

transport of oxygen

[3]

[Total: 10]

2 Alkanes are a type of hydrocarbon.

(a) State what is meant by a hydrocarbon.

.....  
 ..... [2]

(b) Table 2.1 shows some information about some alkanes.

**Table 2.1**

alkane	molecular formula	energy released when 1 g of alkane is completely burned /kJ
methane	CH <sub>4</sub>	55.6
butane	C <sub>4</sub> H <sub>10</sub>	51.7
octane	C <sub>8</sub> H <sub>18</sub>	48.0
eicosane	C <sub>20</sub> H <sub>42</sub>	46.4

The general formula for the alkanes is C<sub>n</sub>H<sub>2n+2</sub>, where **n** is the number of carbon atoms in the molecule.

(i) When **n** increases, the amount of energy released changes.  
 State how the amount of energy released changes.

..... [1]

(ii) Tetradecane is an alkane with 14 carbon atoms.

Write the **molecular formula** for tetradecane.

molecular formula = ..... [1]

(iii) Decene is not an alkane. It has the molecular formula C<sub>10</sub>H<sub>20</sub>.

Use the general formula C<sub>n</sub>H<sub>2n+2</sub> to show that decene is **not** an alkane.

.....  
 ..... [1]

(c) Butane, C<sub>4</sub>H<sub>10</sub>, burns completely in air.

Carbon dioxide and water are made.

Construct the balanced symbol equation for this reaction.

..... [2]

(d) (i) Burning butane is an exothermic reaction.

State what is meant by an exothermic reaction.

.....  
..... [1]

(ii) Use the axes shown in Fig. 2.1 to draw and label the energy level diagram for this reaction.

Label:

- the energy of the reactants and the products
- the energy change in the reaction
- the activation energy of the reaction.

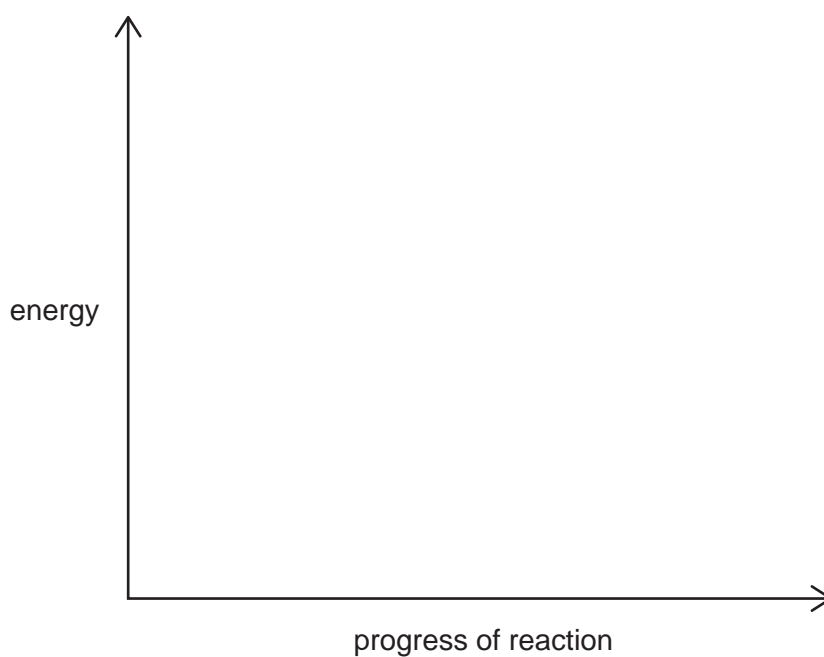

**Fig. 2.1**

[3]

[Total: 11]

6

3 Fig. 3.1 shows a crane lifting a wooden crate.

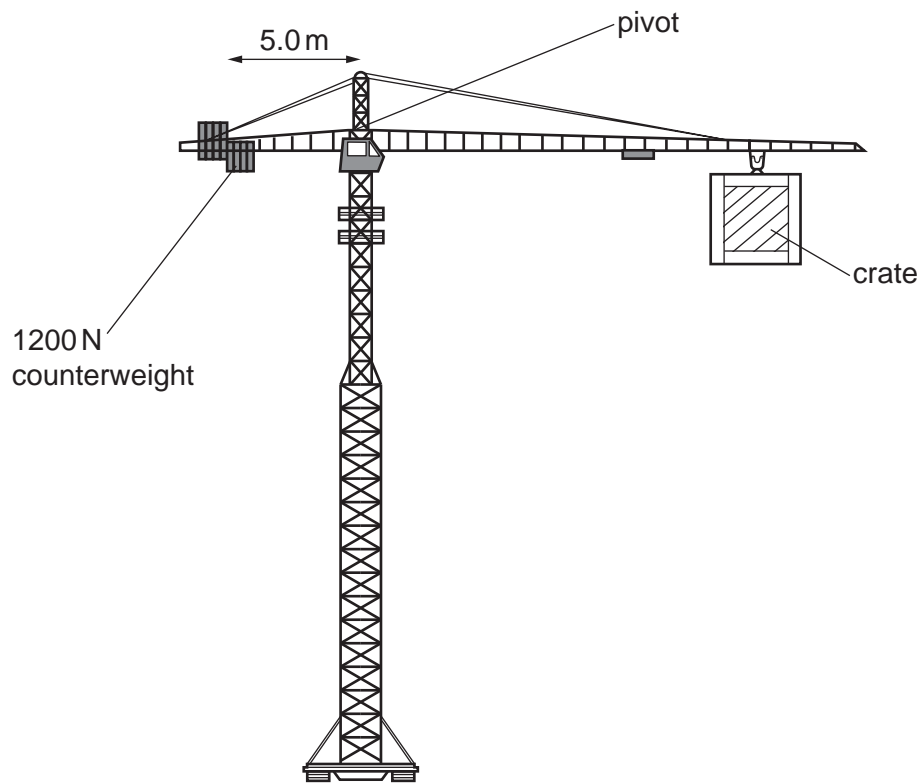

Fig. 3.1

(a) The crane is in equilibrium.

(i) The 1200 N counterweight is 5.0 m away from the pivot.

Calculate the moment of the counterweight about the pivot.

moment = ..... Nm [2]

(ii) Determine the moment of the crate about the pivot.

moment = ..... Nm [1]

(b) The crate gains 105 kJ of gravitational potential energy as it is lifted through a height of 42 m.

Calculate the mass of the crate.

The gravitational field strength,  $g$ , is 10 N/kg.

mass = ..... kg [2]

(c) The crane uses an electric motor.  
Fig. 3.2 shows a simple d.c. motor.

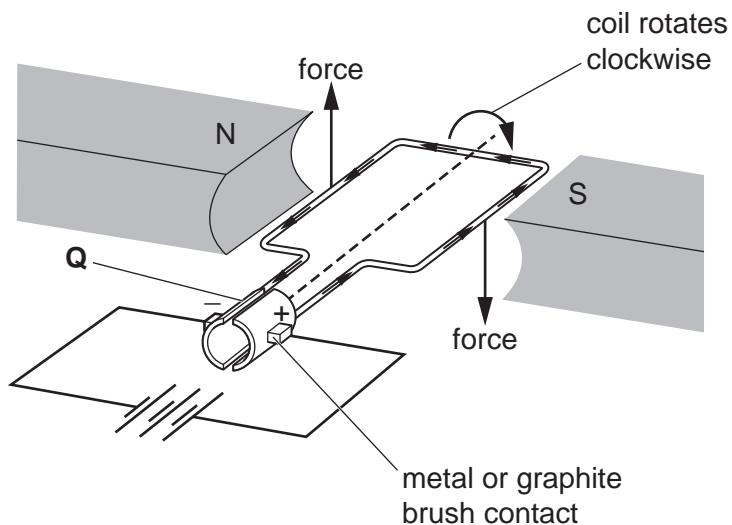

Fig. 3.2

(i) State the name of the component labelled **Q** in Fig. 3.2.  
..... [1]

(ii) Draw an arrow on Fig. 3.2 to show the direction of the magnetic field. [1]

(iii) State **two** ways to increase the speed at which the coil rotates.  
1 .....  
.....  
2 .....  
..... [2]

[Total: 9]

- 4 (a) A seed germinates.

State **two** environmental conditions needed for germination.

1 .....

2 .....

[2]

- (b) A plant is kept in the **dark** to grow.

Fig. 4.1 shows the growth of the plant shoot.

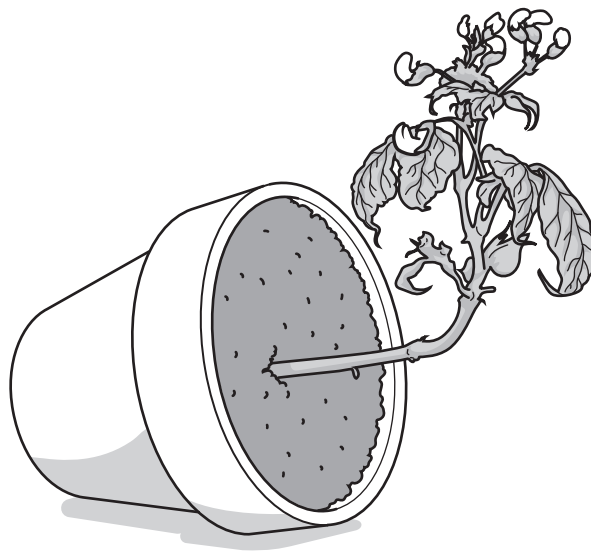

**Fig. 4.1**

- (i) State the name of the tropic response shown in Fig. 4.1.

..... [1]

- (ii) Complete the sentences to explain the mechanism of this growth response.

A plant hormone called ..... is made in the shoot tip and moves through the plant.

The hormone collects on the ..... side of the shoot.

This stimulates growth causing cell .....

The shoot grows away from the direction of .....

[4]



(c) Plants photosynthesise.

(i) State the balanced symbol equation for photosynthesis.

..... [2]

(ii) Explain why chlorophyll is needed for photosynthesis.

.....

.....

..... [2]

[Total: 11]

- 5 (a) Fig. 5.1 shows the arrangement of particles in a **liquid**.

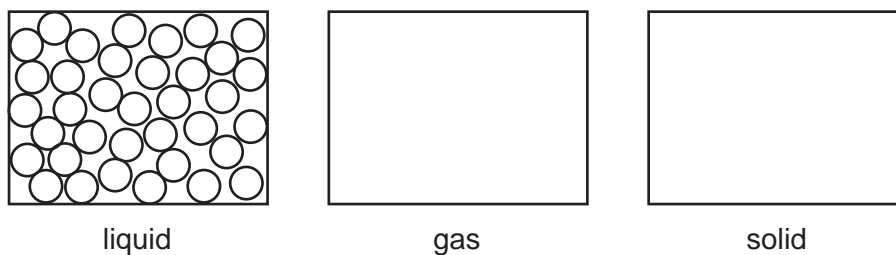

**Fig. 5.1**

Complete Fig. 5.1 to show the arrangement of the particles in a gas and in a solid. [2]

- (b) (i) Liquid water boils at  $100^{\circ}\text{C}$  to form steam.

Describe what happens to the water particles during this change of state.

Include:

- how the arrangement of the particles changes
- how the movement of the particles changes.

arrangement .....

.....

movement .....

.....

[2]

- (ii) Fig. 5.2 shows the bonds between the atoms and the forces between the molecules in water.

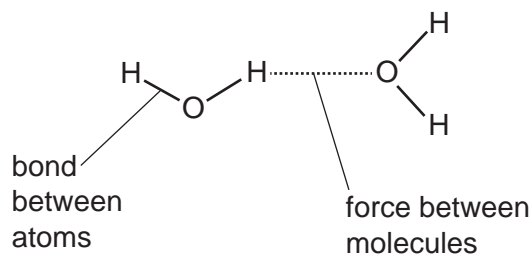

**Fig. 5.2**

When water boils, the forces between the molecules are broken.

Explain why the bonds between atoms are **not** broken.

.....

..... [1]

- (iii) Draw a dot-and-cross diagram to show the bonding in water, H<sub>2</sub>O.  
Show only the outer shell electrons.

[2]

- (c) (i) Water reacts with magnesium metal. The reaction is very slow.

The reaction is faster if **hot** water is used.

Explain why. Use ideas about collisions between particles.

.....  
.....  
..... [2]

- (ii) The reaction between water and magnesium is faster if **powdered** magnesium is used instead of strips of magnesium.

Explain why. Use ideas about collisions between particles.

.....  
.....  
..... [2]

[Total: 11]

- 6 Fig. 6.1 shows a man paddling a canoe on a lake. The arrows show the horizontal forces acting on the canoe.

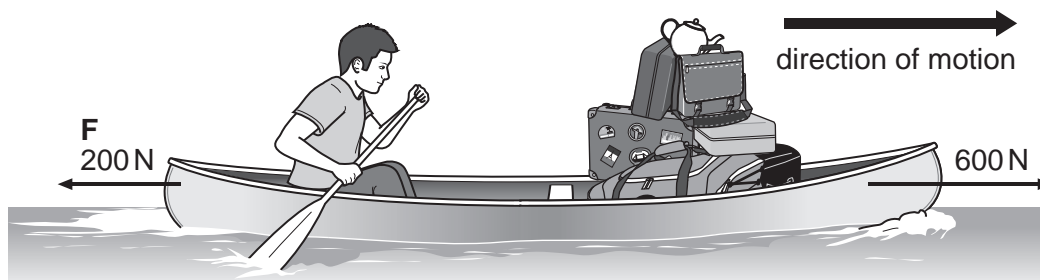

Fig. 6.1

- (a) (i) State the cause of the force labelled **F** on Fig. 6.1.  
 ..... [1]

- (ii) The combined mass of the man and the canoe and his luggage is 100 kg.  
 Calculate the acceleration of the canoe.

acceleration = ..... m/s<sup>2</sup> [3]

- (b) Water waves travel across the surface of the lake.

- (i) The man counts 15 wavefronts passing a point in 1 minute.

Calculate the frequency of the waves in Hz.

frequency = ..... Hz [1]

(ii) The wavelength of the water waves is 0.6 m.

Use your answer to 6(b)(i) to calculate the speed of the water waves.

speed = ..... m/s [2]

(iii) Fig. 6.2 shows the wavefronts of the water waves moving towards two rocks. The water waves will diffract as they travel between the two rocks.

Complete Fig. 6.2 to show how the water waves are diffracted.

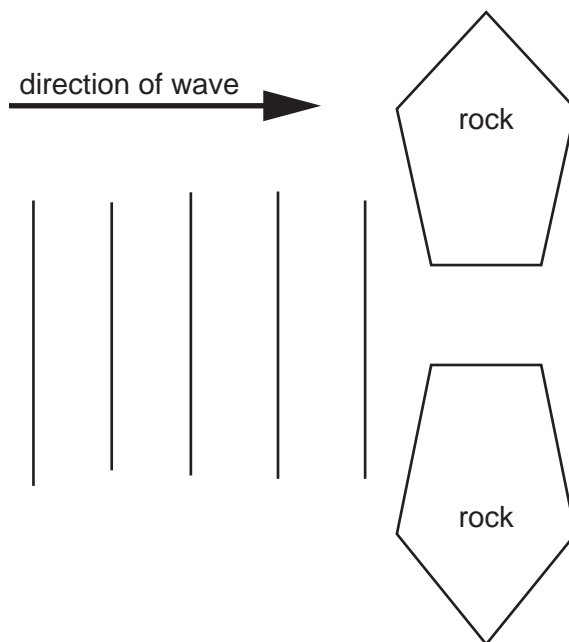

Fig. 6.2

[1]

(c) The man uses a solar panel to charge his mobile phone. The solar panel uses energy from the Sun to generate electricity.

State the name of the process in the Sun that releases energy.

..... [1]

[Total: 9]

- 7 (a) Fig. 7.1 is a photograph of a person with a deficiency disease that has affected their bone growth.

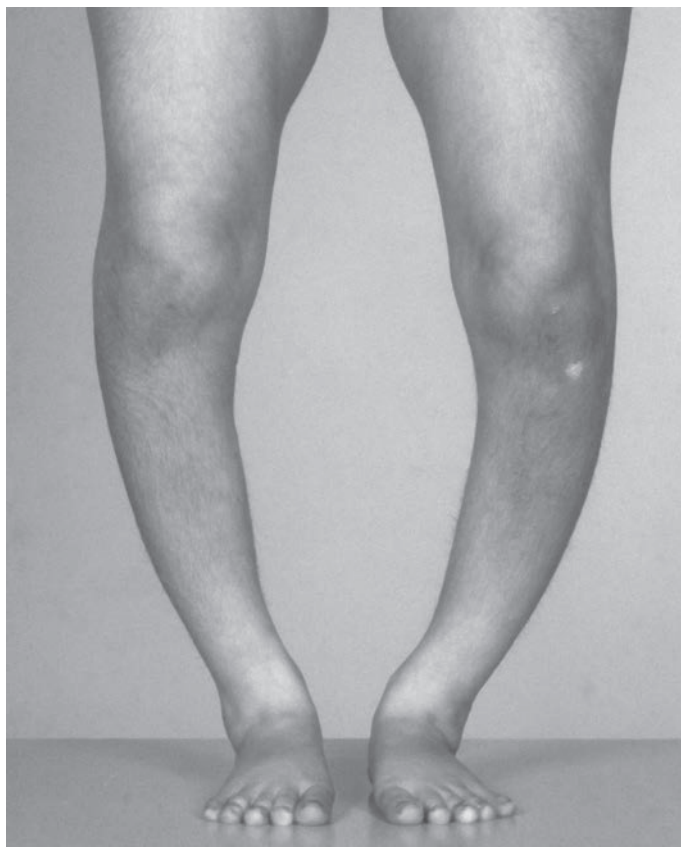

Fig. 7.1

- (i) State the name of the vitamin the person in Fig. 7.1 is deficient in.  
..... [1]
- (ii) Taking vitamin supplements can prevent the deficiency disease shown in Fig. 7.1.  
Suggest **two** other ways to prevent the effects seen in Fig. 7.1.
- 1 .....
- 2 ..... [2]

- (b) Kwashiorkor is a deficiency disease caused by a lack of protein in the diet.

Table 7.1 shows the ages of children admitted to a hospital with kwashiorkor disease.

**Table 7.1**

age group	number of children
4 and under	88
over 4	7
Total	95

- (i) Use Table 7.1 to calculate the percentage of children of age 4 and under with kwashiorkor disease admitted to the hospital.

Give your answer to the nearest whole number.

.....% [2]

- (ii) The recommended daily intake of protein per kg of body mass for a child is greater than that of an adult.

State why.

.....  
 ..... [1]

- (c) State the name of **one** other deficiency disease caused by protein-energy malnutrition.

..... [1]

- (d) State the names of the **four** elements that all proteins contain.

.....  
 ..... [2]

- (e) State the name of the enzyme that breaks down proteins.

..... [1]

[Total: 10]

- 8 Some cars use petrol as a fuel. Some cars use diesel as a fuel.

Table 8.1 shows the mass of pollutant made when 1 kg of petrol or 1 kg of diesel is burnt in a car engine.

**Table 8.1**

pollutant	mass of pollutant/g	
	car using petrol	car using diesel
black smoke	18	0.6
carbon monoxide	236	10
nitrogen monoxide	59	29
sulfur dioxide	3.8	0.9

- (a) (i) Car **A** uses 5 kg of petrol fuel for a journey.

Car **B** uses 8 kg of diesel fuel for the same journey.

State which car, **A** or **B**, makes the most **nitrogen monoxide**.

Explain your answer.

Car ..... makes most nitrogen monoxide.

explanation .....

..... [1]

- (ii) The nitrogen monoxide, NO, made inside the car engine is removed by a catalytic converter.

The nitrogen monoxide is turned into nitrogen gas and oxygen gas.

Construct the balanced symbol equation for this reaction.

..... [2]

- (iii) Sulfur dioxide is a pollutant that causes acid rain.

Sulfur dioxide is not removed from car emissions by a catalytic converter.

Describe **one** way that emissions of sulfur dioxide by cars can be reduced.

.....

..... [1]



(b) A petrol car makes 236 g of carbon monoxide gas when 1 kg of petrol is burnt.

Calculate the volume occupied by 236 g of carbon monoxide gas.

The molar gas volume at room temperature and pressure is  $24 \text{ dm}^3$ .

Show your working.

volume = .....  $\text{dm}^3$  [3]

(c) Sulfur dioxide is used in the manufacture of sulfuric acid in the Contact process.

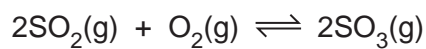

Describe **two** conditions used for this reversible reaction.

1 .....

2 .....

[2]

[Total: 9]

- 9 A student investigates the effect of changing temperature on the current through a thermistor. The student connects a cell, an NTC thermistor, an ammeter and a switch in series.

(a) On Fig. 9.1, complete the circuit diagram to show the circuit used by the student.



Fig. 9.1

[2]

(b) The graph in Fig. 9.2 shows the results obtained by the student.

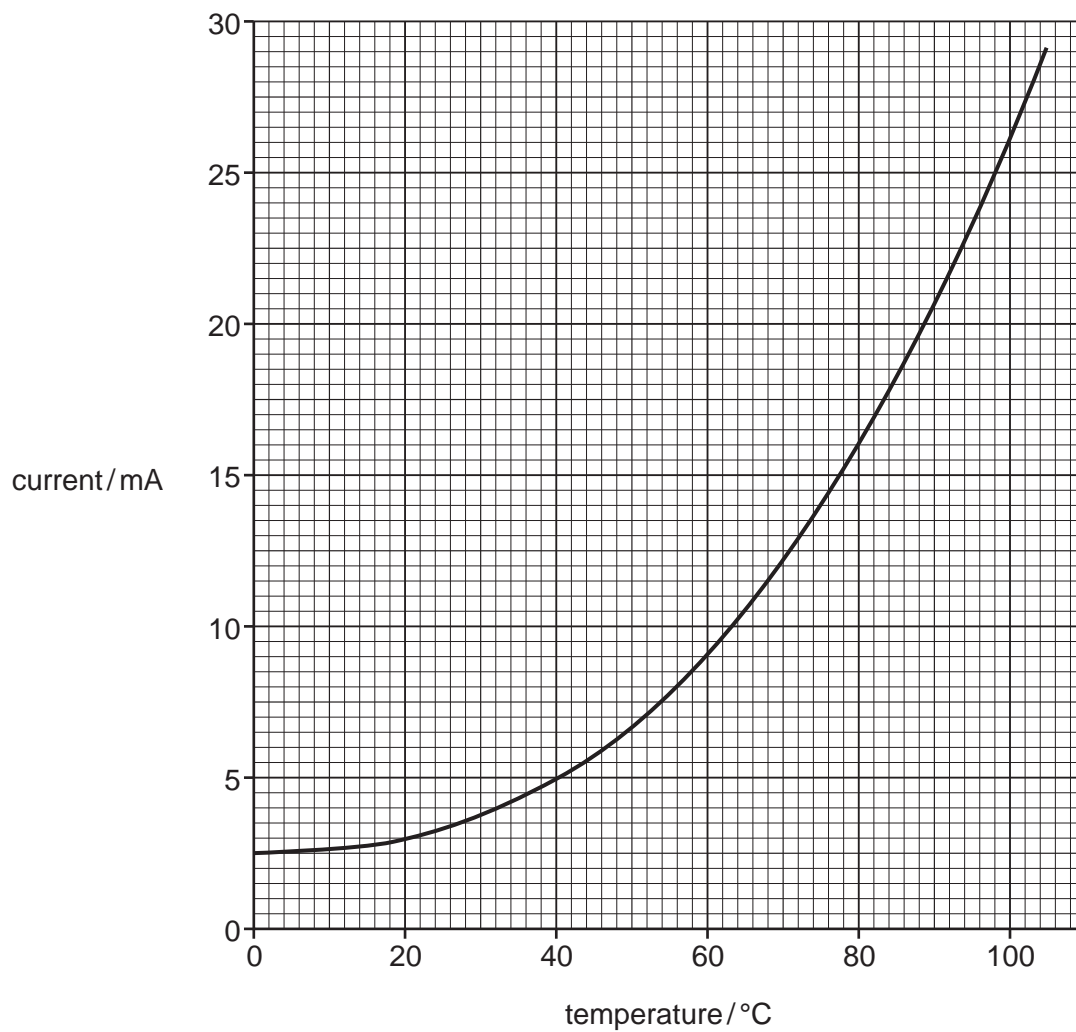

**Fig. 9.2**

The temperature of the thermistor is 40°C.

Calculate the time it takes for 1.0C of charge to flow through the thermistor.

time = ..... s [3]

- (c) The student uses a liquid-in-glass thermometer to measure temperature.

Fig. 9.3 shows the structure of a liquid-in-glass thermometer.

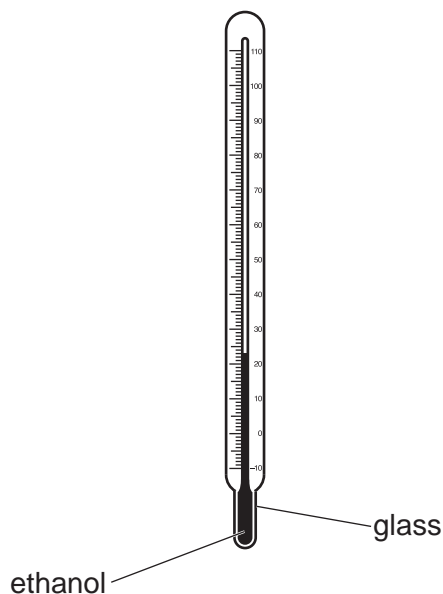

**Fig. 9.3**

- (i) Thermal energy is transferred through the glass to the ethanol.

Describe how thermal energy is transferred through glass.

.....

.....

..... [2]

- (ii) The ethanol in the thermometer expands as the temperature increases.

Explain why the ethanol expands as the temperature increases in terms of the motion and arrangement of molecules.

.....

.....

.....

..... [2]

21

- (iii) The volume of the ethanol in the thermometer at 25 °C is 2.00 cm<sup>3</sup> and the density of the ethanol is 0.78 g/cm<sup>3</sup>.

When the thermometer is cooled to 3 °C, the volume decreases to 1.95 cm<sup>3</sup>.

Calculate the density of the ethanol at 3 °C.

density of ethanol = ..... g/cm<sup>3</sup> [3]

[Total: 12]

10 (a) Fig. 10.1 is a diagram of a cross-section through skin.

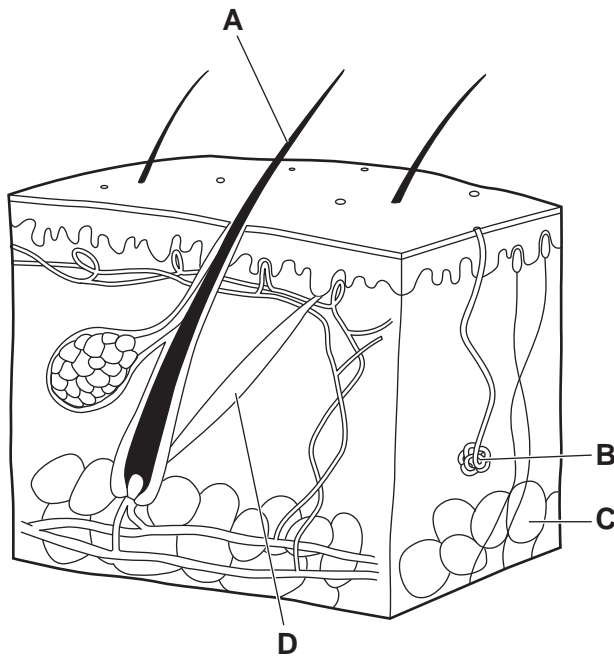

Fig. 10.1

Table 10.1 shows the names and functions of some of the parts labelled A–D in Fig. 10.1.

Complete Table 10.1.

Table 10.1

name of part	letter in Fig. 10.1	function
		provide insulation
hair erector muscle		
	<b>B</b>	

[3]

(b) Describe the role of **arterioles** in reducing body temperature when the body gets too hot.

.....

.....

.....

.....

.....

.....

[3]

(c) The control of internal body temperature is an example of negative feedback.

(i) Explain what is meant by the term negative feedback.

.....  
.....  
..... [2]

(ii) State **one** other example of negative feedback.

..... [1]

[Total: 9]

- 11 (a) Copper oxide,  $\text{CuO}$ , is heated with carbon,  $\text{C}$ .

Copper,  $\text{Cu}$ , and carbon dioxide,  $\text{CO}_2$ , are made as shown in the equation:

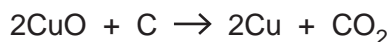

This reaction is an example of reduction.

Use the equation to explain what reduction means.

.....  
 ..... [1]

- (b) The copper made from copper oxide is not pure.

A student purifies the impure copper using electrolysis.

Fig. 11.1 shows the apparatus the student uses.

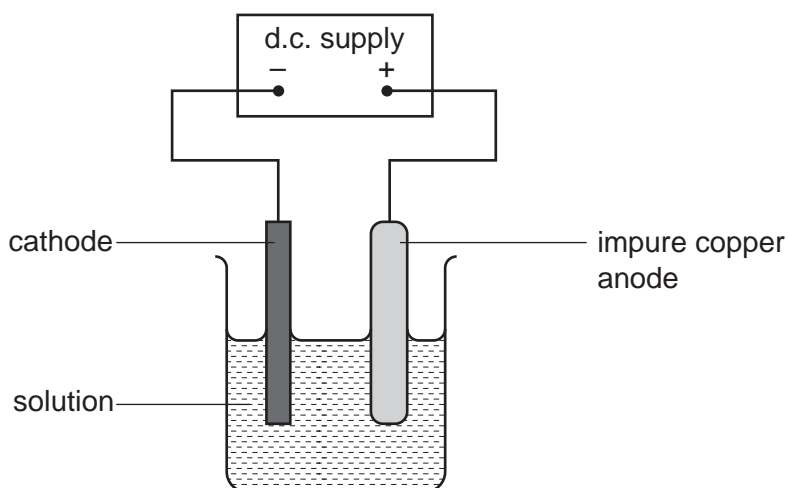

Fig. 11.1

- (i) State the name of the electrolyte solution the student uses.

..... [1]

- (ii) The student uses impure copper as the anode.

State what the student uses as the cathode.

..... [1]

- (c) Copper atoms are formed from copper ions,  $\text{Cu}^{2+}$ , at the cathode.

Construct the balanced ionic half-equation for this reaction.

Use the symbol  $\text{e}^-$  for an electron.

..... [2]



(d) Aluminium is a metal that is extracted by electrolysis.

Fig. 11.2 shows the apparatus that is used.

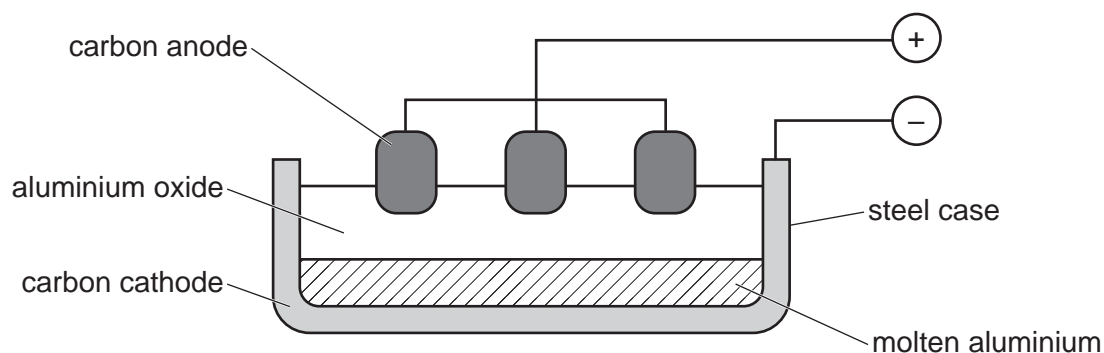

Fig. 11.2

The word equation for the electrolysis of aluminium oxide is:



(i) State what is made at the cathode.

..... [1]

(ii) Oxide ions lose electrons to form oxygen molecules.

The ionic half-equation for the reaction is:



Electrons are lost during this process.

State the name of this type of reaction.

..... [1]

(e) Aluminium reacts with oxygen to make aluminium oxide,  $\text{Al}_2\text{O}_3$ .

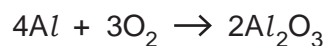

Calculate the maximum mass of aluminium oxide that can be made from 1.35g of aluminium.  
Show your working.

mass of aluminium oxide = ..... g [2]

[Total: 9]

12  $\alpha$ -particles,  $\beta$ -particles and  $\gamma$ -rays are all forms of ionising radiation.

(a) State **one** effect of ionising radiation on living things.

..... [1]

(b) The radioactive isotope uranium-238 decays into the isotope thorium-234 by emitting an  $\alpha$ -particle.

Use the correct nuclide notation to complete the decay equation for uranium-238.

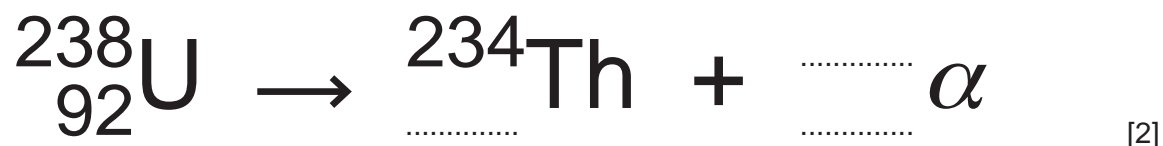

(c) Gamma radiation is part of the electromagnetic spectrum.

(i) State the speed of gamma radiation in a vacuum.

..... [1]

(ii) Draw lines to match each form of electromagnetic radiation to its use. One line has been drawn for you.

form of electromagnetic radiation	use
infrared	medicine and security
microwaves	radio and TV communications
radio waves	remote controls and intruder alarms
X-rays	satellite television and telephones

[2]

- (d) Visible light is also part of the electromagnetic spectrum.  
Fig. 12.1 shows an object emitting visible light and a thin converging lens.

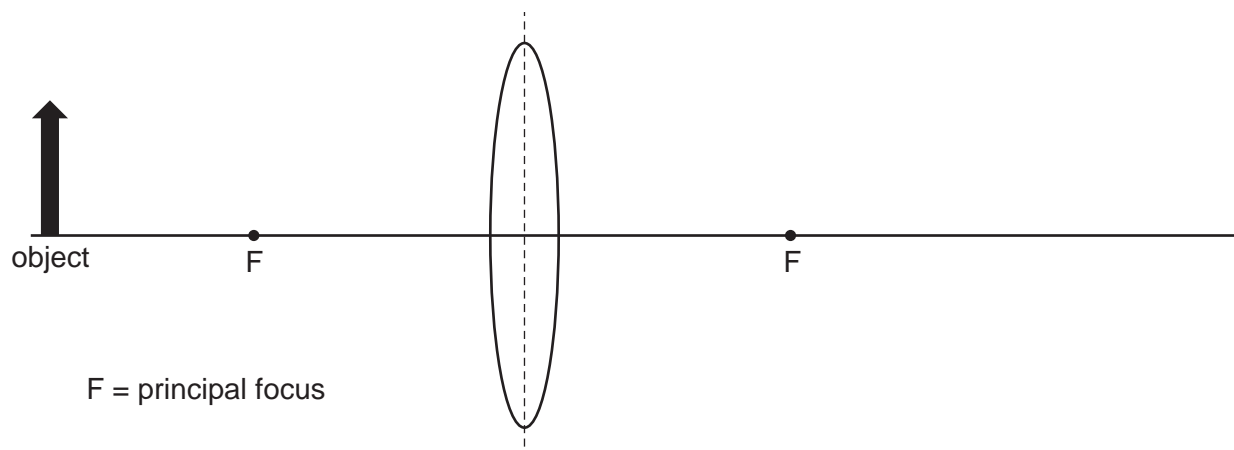

**Fig. 12.1**

- (i) Complete Fig. 12.1 to show how the rays of light from the object form an image. [3]
- (ii) The image formed is a **real** image.

State **one** difference between a real image and a virtual image.

.....

..... [1]

[Total: 10]

## The Periodic Table of Elements

Group																							
I	II																III	IV	V	VI	VII	VIII	
3 <b>Li</b> lithium 7	4 <b>Be</b> beryllium 9	<b>Key</b> atomic number atomic symbol name relative atomic mass																5 <b>B</b> boron 11	6 <b>C</b> carbon 12	7 <b>N</b> nitrogen 14	8 <b>O</b> oxygen 16	9 <b>F</b> fluorine 19	10 <b>Ne</b> neon 20
11 <b>Na</b> sodium 23	12 <b>Mg</b> magnesium 24																	13 <b>Al</b> aluminium 27	14 <b>Si</b> silicon 28	15 <b>P</b> phosphorus 31	16 <b>S</b> sulfur 32	17 <b>Cl</b> chlorine 35.5	18 <b>Ar</b> argon 40
19 <b>K</b> potassium 39	20 <b>Ca</b> calcium 40	21 <b>Sc</b> scandium 45	22 <b>Ti</b> titanium 48	23 <b>V</b> vanadium 51	24 <b>Cr</b> chromium 52	25 <b>Mn</b> manganese 55	26 <b>Fe</b> iron 56	27 <b>Co</b> cobalt 59	28 <b>Ni</b> nickel 59	29 <b>Cu</b> copper 64	30 <b>Zn</b> zinc 65	31 <b>Ga</b> gallium 70	32 <b>Ge</b> germanium 73	33 <b>As</b> arsenic 75	34 <b>Se</b> selenium 79	35 <b>Br</b> bromine 80	36 <b>Kr</b> krypton 84						
37 <b>Rb</b> rubidium 85	38 <b>Sr</b> strontium 88	39 <b>Y</b> yttrium 89	40 <b>Zr</b> zirconium 91	41 <b>Nb</b> niobium 93	42 <b>Mo</b> molybdenum 96	43 <b>Tc</b> technetium —	44 <b>Ru</b> ruthenium 101	45 <b>Rh</b> rhodium 103	46 <b>Pd</b> palladium 106	47 <b>Ag</b> silver 108	48 <b>Cd</b> cadmium 112	49 <b>In</b> indium 115	50 <b>Sn</b> tin 119	51 <b>Sb</b> antimony 122	52 <b>Te</b> tellurium 128	53 <b>I</b> iodine 127	54 <b>Xe</b> xenon 131						
55 <b>Cs</b> caesium 133	56 <b>Ba</b> barium 137	57–71 lanthanoids	72 <b>Hf</b> hafnium 178	73 <b>Ta</b> tantalum 181	74 <b>W</b> tungsten 184	75 <b>Re</b> rhenium 186	76 <b>Os</b> osmium 190	77 <b>Ir</b> iridium 192	78 <b>Pt</b> platinum 195	79 <b>Au</b> gold 197	80 <b>Hg</b> mercury 201	81 <b>Tl</b> thallium 204	82 <b>Pb</b> lead 207	83 <b>Bi</b> bismuth 209	84 <b>Po</b> polonium —	85 <b>At</b> astatine —	86 <b>Rn</b> radon —						
87 <b>Fr</b> francium —	88 <b>Ra</b> radium —	89–103 actinoids	104 <b>Rf</b> rutherfordium —	105 <b>Db</b> dubnium —	106 <b>Sg</b> seaborgium —	107 <b>Bh</b> bohrium —	108 <b>Hs</b> hassium —	109 <b>Mt</b> meitnerium —	110 <b>Ds</b> darmstadtium —	111 <b>Rg</b> roentgenium —	112 <b>Cn</b> copernicium —	114 <b>Fl</b> flerovium —	116 <b>Lv</b> livermorium —	—	—	—	—						

57 <b>La</b> lanthanum 139	58 <b>Ce</b> cerium 140	59 <b>Pr</b> praseodymium 141	60 <b>Nd</b> neodymium 144	61 <b>Pm</b> promethium —	62 <b>Sm</b> samarium 150	63 <b>Eu</b> europium 152	64 <b>Gd</b> gadolinium 157	65 <b>Tb</b> terbium 159	66 <b>Dy</b> dysprosium 163	67 <b>Ho</b> holmium 165	68 <b>Er</b> erbium 167	69 <b>Tm</b> thulium 169	70 <b>Yb</b> ytterbium 173	71 <b>Lu</b> lutetium 175
89 <b>Ac</b> actinium —	90 <b>Th</b> thorium 232	91 <b>Pa</b> protactinium 231	92 <b>U</b> uranium 238	93 <b>Np</b> neptunium —	94 <b>Pu</b> plutonium —	95 <b>Am</b> americium —	96 <b>Cm</b> curium —	97 <b>Bk</b> berkelium —	98 <b>Cf</b> californium —	99 <b>Es</b> einsteinium —	100 <b>Fm</b> fermium —	101 <b>Md</b> mendelevium —	102 <b>No</b> nobelium —	103 <b>Lr</b> lawrencium —

The volume of one mole of any gas is 24 dm<sup>3</sup> at room temperature and pressure (r.t.p.).